

OFFSET NOTES:
 1) POST OFFSET DIMENSIONS ARE GIVEN TO THE CENTER OF THE TRAFFIC FACE OF THE BLOCKOUTS, EXCEPT AT THE FIRST TWO POSTS, WHERE THE DIMENSION IS TO THE CENTER OF THE TRAFFIC FACE OF POST.
 2) GUARDRAIL BETWEEN POST 1-7 IS ON A STRAIGHT LINE FLARE.

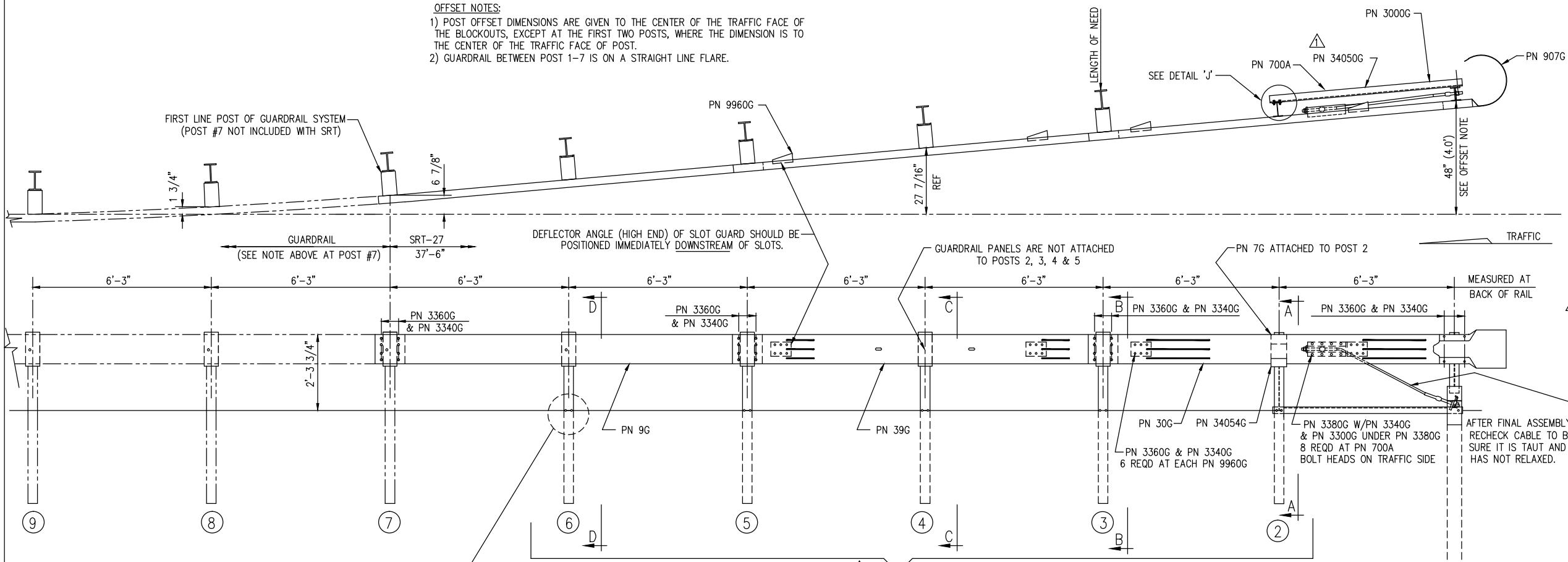

BILL OF MATERIAL		
PN	QTY	DESCRIPTION
7G	1	12/6"/FLG PROTECTOR (AT POST 2)
9G	1	12/12'6"/6'3"/S (GUARDRAIL)
30G	1	12/12'6"/S SRT-1 (GUARDRAIL)
39G	1	12/12'6"/S SRT-2 (GUARDRAIL)
700A	1	CABLE ANCHOR BRACKET
907G	1	12/BUFFER/ROLLED (TERMINAL)
3000G	1	3/4 x 6'-6" CABLE
4076B	4	6"x8"x14" ROUTED WOOD BLOCK
3240G	2	5/16" WASHER (AT POST 1)
3245G	2	5/16" HEX NUT (AT POST 1)
3300G	10	5/8" WASHER
3340G	68	5/8" HEX HGR NUT
3360G	52	5/8" x 1 1/4" HGR SPLICE BOLT
3380G	8	5/8" x 1 1/2" HEX HD BOLT (AT CBL BRKT)
3400G	3	5/8" x 2" HGR POST BOLT (AT POST 1 & 2)
3391G	1	5/8" x 1 3/4" HEX BOLT (A325) (AT STRUT)
3900G	2	1" WASHER (AT CABLE)
3910G	2	1" HEX NUT (AT CABLE)
4211G	2	5/16" x 1 3/4" HEX BOLT (AT POST 1)
3500G	4	5/8" x 10" HGR POST BOLT (AT POST 3-6)
4389G	2	7/16" FLAT WASHER
4390G	2	7/16" x 1 1/2" HEX HD BOLT (AT STRUT)
4393G	2	7/16" LOCK WASHER
4396G	2	7/16" HEX NUT
9960G	4	SLOT GUARD BRACKET
14578G	5	6'-0" SYT POST (W6 X 8.5)
33909G	1	CABLE ANCHOR BRACKET (AT POST 1)
34050G	1	SRT/CRP/SYTP STRUT 3 x 3 x 1/4 x 6'-9"
34052A	1	CR POST 1 BOT (W6 x 15)
34056A	1	CR POST 1 TOP (W6 x 8.5)
34054G	1	POST SHELF ANGLE (AT POST 2)

HARDWARE

AFTER FINAL ASSEMBLY, RECHECK CABLE TO BE SURE IT IS TAUT AND HAS NOT RELAXED.

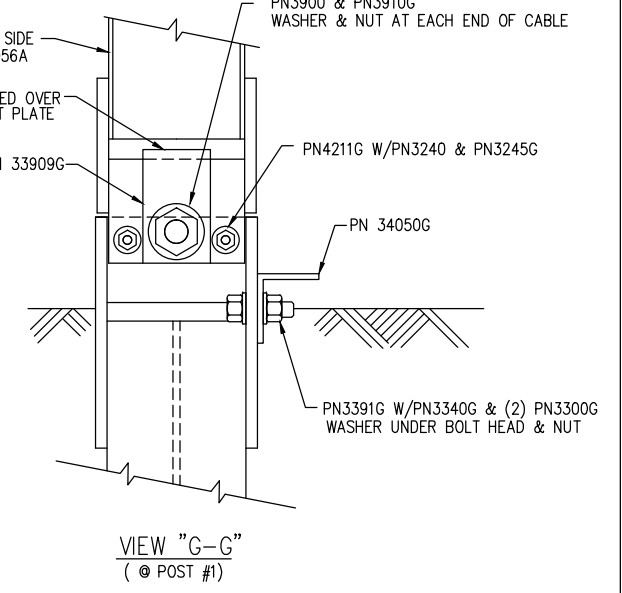
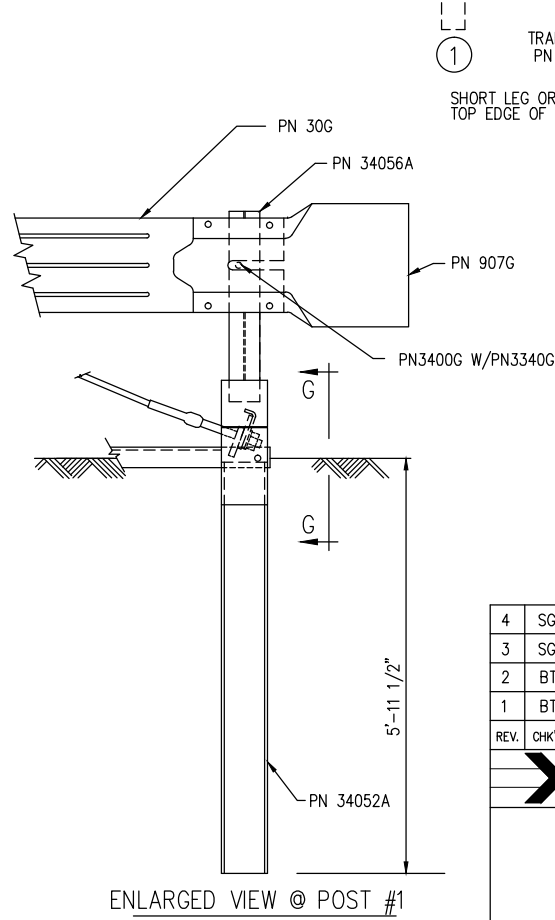
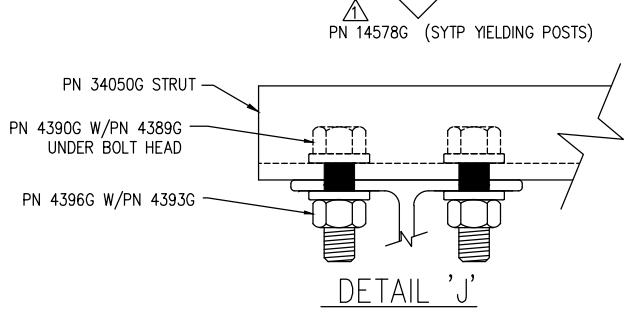
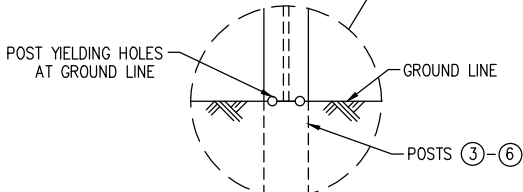

NOTES:
 1.) PLASTIC OFFSET BLOCKS (ROUTED) ARE ACCEPTABLE ALTERNATES.

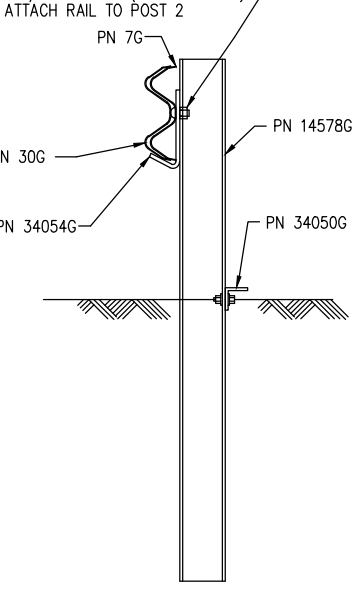
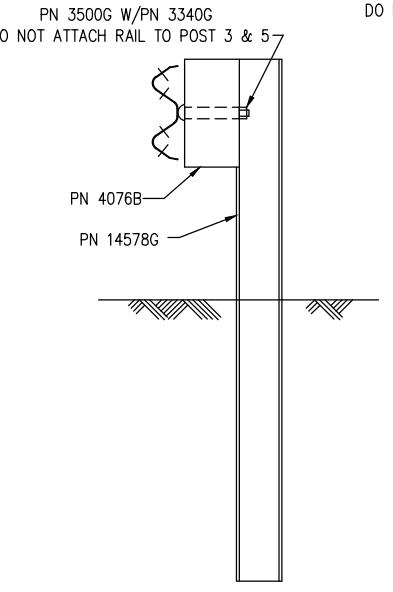
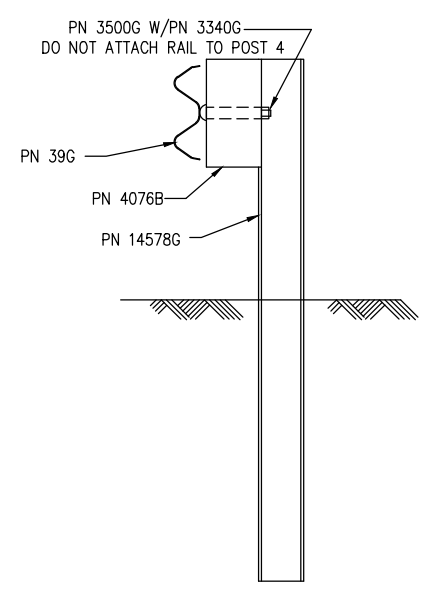
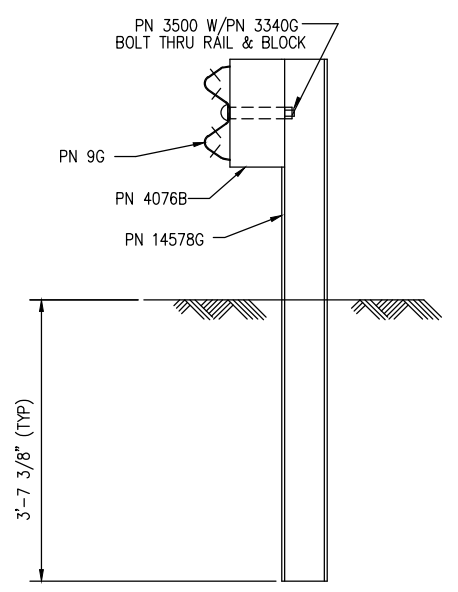

REV.	CHK'D	BY	DATE	REMARKS
4	SG	LH	3/06/12	ADDED PLASTIC ROUTED BLOCK NOTE
3	SG	BT	9/28/10	OFFSETED POSTS 7 AND 8
2	BT	LH	2/26/09	REMOVED HARDWARE NOTE @ POST #2 (sect A-A): REVISED HARDWARE
1	BT	LH	2/23/09	REVISED POSTS 2-6: REVISED STRUT: REVISED HARDWARE

SRT-27

SLOTTED RAIL TERMINAL SRT-27
ERECTION DETAILS
(3 PANELS, CR AND SYT POSTS)

DRAWN	LH
CHECKED	BT
SCALE	N.T.S.
DATE	07/24/08
ENG. FILE #	SS446-01E
SHT.No.	E1 OF 1
DRAWING NO.	SS 446
REV.	4

TRINITY HIGHWAY PRODUCTS, LLC.
2525 STEMMONS FREEWAY
DALLAS, TX 75207

The drawings and the information shown thereon are copyrighted by Trinity Highway Products (2010) and the sole property of Trinity Highway Products. Neither the drawings nor such information is to be used for any purpose other than that for which it was specifically furnished from Trinity Highway Products, LLC., nor is any reproduction authorized without written permission.