

- NOTES:**
- CASS-TL4 HAS BEEN SUCCESSFULLY TESTED AT VARIOUS POST SPACING AND APPROVED TO NATIONAL COOPERATIVE HIGHWAY RESEARCH PROGRAM REPORT 350 TEST LEVEL 3 (NCHRP 350 TL-3). CASS CABLE TERMINAL (CCT) HAS BEEN SUCCESSFULLY TESTED AND APPROVED TO NCHRP 350 TL-3.
 - AN NCHRP 350 TL-3 APPROVED TERMINAL (CCT) OR CASS-TL4 TRANSITION (VARIOUS) SHALL BE USED ON APPROACH AND DEPARTURE TERMINATIONS WHEN CASS-TL4 IS INSTALLED ON THE NATIONAL HIGHWAY SYSTEM (NHS). IF THE TERMINATION POINT IS LOCATED OUTSIDE THE CLEAR ZONE AND/OR PROTECTED BY OTHER MEANS (CRASHWORTHY BARRIER, TERMINALS, ETC.), A NON-NCHRP 350 TL-3 ANCHOR (CCA) MAY BE USED ON APPROACH AND DEPARTURE TERMINATIONS - SEE SS-740A.
 - CASS-TL4 SHALL BE INSTALLED ON SHOULDERS OR MEDIANS WITH SLOPES OF 6:1 OR FLATTER WITHOUT OBSTRUCTIONS, DEPRESSIONS, ETC. THAT MAY SIGNIFICANTLY AFFECT THE STABILITY OF AN ERRANT VEHICLE. GRADING OF SITE AND/OR APPROPRIATE FILL MATERIALS MAY BE REQUIRED. THE DESIGNER/INSTALLER SHALL "FLATTEN" OR "ROUND" VARIOUS TOPOGRAPHICAL INCONSISTENCIES THAT COULD INTERFERE WITH THE ABILITY OF THE INSTALLER TO CONSISTENTLY MAINTAIN THE DESIGN HEIGHT (IN RELATION TO THE TERRAIN) OF THE CABLES. PLEASE CONSULT THE CASS MANUAL(S) FOR INSTALLATIONS IN "DITCH SECTIONS".
 - CASS-TL4 POST SPACING MAY BE MODIFIED TO AVOID OBSTACLES THAT CONFLICT WITH THE INSTALLATION OF CASS-TL4 LINE POSTS. NO POST SPACE CAN EXCEED THE MAXIMUM POST SPACE LIMIT OF 32'-6", OR MAXIMUM POST SPACING ALLOWED BY PROJECT ENGINEER - WHICHEVER IS LESS. REDUCING OR INCREASING POST SPACING AFFECTS DEFLECTION. CASS-TL4 MAY BE LATERALLY TRANSFERRED AT A RATE NOT TO EXCEED 30:1.
 - POST FOUNDATIONS MAY BE DRILLED THROUGH EXISTING PAVEMENT. PLEASE SEE LINE POST FOUNDATION CHART FOR MINIMUM FOOTING REQUIREMENTS IN VARIOUS APPLICATIONS. FOR AESTHETIC PURPOSES CASS SLEEVES, DRIVEN POSTS, AND LOWER CABLE RELEASE POSTS SHALL BE INSTALLED NO MORE THAN 1/8" PER FOOT OUT OF PLUMB.
 - ALL CONCRETE SHALL HAVE A MINIMUM COMPRESSIVE STRENGTH OF 3,000 P.S.I. PRIOR TO TENSIONING THE SYSTEM. TRINITY RECOMMENDS THE CONCRETE TO BE VIBRATED IN ACCORDANCE WITH THE LATEST APPLICABLE AGENCY SPECIFICATION.
 - CASS-TL4 SHALL BE INSTALLED IN WELL-DRAINED, COMPACTED, NCHRP REPORT 350 STANDARD SOIL. IF SOIL DOESN'T MEET THIS CLASSIFICATION, IF SOLID ROCK/CONCRETE IS ENCOUNTERED BELOW GRADE OR IF SOIL IS SUSCEPTIBLE TO SEVERE FREEZE/THAW CYCLES, PLEASE CONTACT TRINITY ABOUT ALTERNATE FOOTING DESIGN(S). TRINITY SUGGESTS THE USE OF "MOW STRIPS" FOR EROSION PREVENTION AND EASE OF MAINTENANCE / INSTALLATION.
 - PLEASE SEE SPECIFYING AGENCY (OR MUTCD) FOR PROPER "BARRIER" DELINEATION.
 - PLEASE CONTACT TRINITY OR CONSULT THE DESIGN, INSTALLATION, OR REPAIR MANUAL(S) FOR ADDITIONAL INFORMATION.

TRINITY HIGHWAY PRODUCTS, LLC. EMAIL: PRODUCT.INFO@TRIN.NET
 2525 STEMMONS FREEWAY DALLAS, TX 75207 PHONE: (800) 644-7976

MOW STRIP DETAIL*			CONCRETE FOOTING CHART		
MOW STRIP	DEPTH	WIDTH	FOOTING	TUBE SLEEVE	REBAR RING
NONE			30" MIN	27" MIN.	YES
HMA	6" MIN.	3" MIN.	27" MIN	15" MIN.	NO
HMA	8" MIN.	3" MIN.	24" MIN	15" MIN.	NO
RC	3" MIN.	3" MIN.	24" MIN	15" MIN.	NO

CHART DOES NOT APPLY TO TERMINAL POSTS 1 THRU 9
 * MOW STRIP OR PAVEMENT
 HMA = HOT MIX ASPHALT (NOT RECYCLED ASPHALT PAVEMENT)
 RC = REINFORCED CONCRETE (3,000 P.S.I. MINIMUM)

No.	CASS-TL4 POST OPTIONS
1	CCT - TERMINAL POST 1 - 9 - IN CONCRETE
2	CCT - TERMINAL POST 1 - 9 - WITH SOIL PLATE
3	CASS-TL4 POST - IN CONCRETE
4	CASS-TL4 POST - DRIVEN
5	CASS-TL4 POST - BASE-PLATED
6	CASS-TL4 POST - IN DRIVEN SLEEVE
	6A - DRIVEN SLEEVE - WITH NOTCH
	6B - DRIVEN SLEEVE - WITH SOIL PLATE

CASS-TL4 CABLE GUARDRAIL SAFETY SYSTEM

TRINITY HIGHWAY PRODUCTS, LLC

GALV SPEC:
 SHIPPING WT:
 DRW: E.A.S. 6/13/2007
 CHK: G.N. 6/13/2007
 SH: 1 OF 5 SIZE: D
 DWG NO: SS-740 REV: 0

PARTS LIST - CASS-TL4 POST - IN CONCRETE - POST OPTION #3			
QTY	PART No	TITLE	Lbs / Each
2	5703B	CASS-TL4 CABLE SPACER	0.24
1	5707T	CASS-TL - POST STRAP	0.23
1	5708B	SLEEVE COVER - CASS-TL POST	0.11
1	5747B	SLEEVE CAP - CASS-TL POST	0.14
1	5836B	CONCRETE REINFORCING RING	0.88
1	33954G	CASS-TL4 POST - CONCRETE	34.50
1	33982G	27" POST SLEEVE - IN CONCRETE	14.48

PARTS LIST - CASS-TL4 POST DRIVEN - OPTION #4			
QTY	PART No	TITLE	Lbs / Each
2	5703B	CASS-TL4 CABLE SPACER	0.24
1	5707T	CASS-TL - POST STRAP	0.23
1	33957G	CASS-TL4 POST - DRIVEN	50.62

PARTS LIST - CASS-TL4 POST BASE-PLATED - OPTION #5			
QTY	PART No	TITLE	Lbs / Each
4	3310G	5/8 LOCK WASHER	0.00
4	3361G	5/8" HEX NUT (A563 Gr DH)	0.01
4	4372G	5/8" FLAT WASHER (F436)	0.00
2	5703B	CASS-TL4 CABLE SPACER	0.24
1	5707T	CASS-TL - POST STRAP	0.23
4	6722G	5/8 ALL THREADED ROD CHISEL POINT (A449)	0.69
1	33994A	POST-TL4 - BASE PLATED	35.58

PARTS LIST - CASS-TL4 POST - IN DRIVEN SLEEVE - POST OPTION #6A			
QTY	PART No	TITLE	Lbs / Each
2	5703B	CASS-TL4 CABLE SPACER	0.24
1	5707T	CASS-TL - POST STRAP	0.23
1	5708B	SLEEVE COVER - CASS-TL POST	0.11
1	33954G	CASS-TL4 POST - CONCRETE	34.50
1	33975G	30.75" POST SLEEVE - DRIVEN SHORT POST	16.42

PARTS LIST - PRE-STRETCHED CABLE ASSEMBLIES						
QTY	PART No	TITLE	LENGTH	TERM-1	TERM-2	Lbs / Each
1	5817	CCT CABLE ASSEMBLY-TOP	54'-4"	R.H.T.	L.H.T.	58.3
1	5818	CCT CABLE ASSEMBLY-MID	48'-1"	R.H.T.	L.H.T.	52.3
1	5819	CCT CABLE ASSEMBLY-BOT	41'-10"	R.H.T.	L.H.T.	46.3
1	5867	CCA CABLE ASSEMBLY	25'-0"	R.H.T.	L.H.T.	30.9
1	5816	CABLE ASSEMBLY-INTERIOR	1000'	R.H.T.	L.H.T.	967.0
1	5753	CABLE FIELD SPLICE SECTION	1025'	R.H.T.	NONE	989.0
1	5752	CABLE FIELD SPLICE SECTION	1000'	R.H.T.	NONE	965.0
1	5798	CABLE FIELD SPLICE SECTION	975'	R.H.T.	NONE	940.9
1	5797	CABLE FIELD SPLICE SECTION	950'	R.H.T.	NONE	916.9
1	5796	CABLE FIELD SPLICE SECTION	925'	R.H.T.	NONE	892.8
1	5795	CABLE FIELD SPLICE SECTION	900'	R.H.T.	NONE	868.8
1	5794	CABLE FIELD SPLICE SECTION	875'	R.H.T.	NONE	844.7
1	5793	CABLE FIELD SPLICE SECTION	850'	R.H.T.	NONE	820.7
1	5792	CABLE FIELD SPLICE SECTION	825'	R.H.T.	NONE	796.6
1	5791	CABLE FIELD SPLICE SECTION	800'	R.H.T.	NONE	772.6
1	5790	CABLE FIELD SPLICE SECTION	775'	R.H.T.	NONE	748.5
1	5789	CABLE FIELD SPLICE SECTION	750'	R.H.T.	NONE	724.5
1	5788	CABLE FIELD SPLICE SECTION	725'	R.H.T.	NONE	700.4
1	5787	CABLE FIELD SPLICE SECTION	700'	R.H.T.	NONE	676.4
1	5786	CABLE FIELD SPLICE SECTION	675'	R.H.T.	NONE	652.3
1	5785	CABLE FIELD SPLICE SECTION	650'	R.H.T.	NONE	628.3
1	5784	CABLE FIELD SPLICE SECTION	625'	R.H.T.	NONE	604.2
1	5783	CABLE FIELD SPLICE SECTION	600'	R.H.T.	NONE	580.2
1	5782	CABLE FIELD SPLICE SECTION	575'	R.H.T.	NONE	556.1
1	5781	CABLE FIELD SPLICE SECTION	550'	R.H.T.	NONE	532.1
1	5780	CABLE FIELD SPLICE SECTION	525'	R.H.T.	NONE	508.0
1	5779	CABLE FIELD SPLICE SECTION	500'	R.H.T.	NONE	484.0
1	5778	CABLE FIELD SPLICE SECTION	475'	R.H.T.	NONE	459.9
1	5777	CABLE FIELD SPLICE SECTION	450'	R.H.T.	NONE	435.9
1	5776	CABLE FIELD SPLICE SECTION	425'	R.H.T.	NONE	411.8
1	5775	CABLE FIELD SPLICE SECTION	400'	R.H.T.	NONE	387.8
1	5774	CABLE FIELD SPLICE SECTION	375'	R.H.T.	NONE	363.7
1	5773	CABLE FIELD SPLICE SECTION	350'	R.H.T.	NONE	339.7
1	5772	CABLE FIELD SPLICE SECTION	325'	R.H.T.	NONE	315.7
1	5771	CABLE FIELD SPLICE SECTION	300'	R.H.T.	NONE	291.6
1	5770	CABLE FIELD SPLICE SECTION	275'	R.H.T.	NONE	267.6
1	5769	CABLE FIELD SPLICE SECTION	250'	R.H.T.	NONE	243.5
1	5768	CABLE FIELD SPLICE SECTION	225'	R.H.T.	NONE	219.5
1	5767	CABLE FIELD SPLICE SECTION	200'	R.H.T.	NONE	195.4
1	5766	CABLE FIELD SPLICE SECTION	175'	R.H.T.	NONE	171.4
1	5765	CABLE FIELD SPLICE SECTION	150'	R.H.T.	NONE	147.3
1	5764	CABLE FIELD SPLICE SECTION	125'	R.H.T.	NONE	123.3
1	5763	CABLE FIELD SPLICE SECTION	100'	R.H.T.	NONE	99.2
1	5762	CABLE FIELD SPLICE SECTION	75'	R.H.T.	NONE	75.2
1	5761	CABLE FIELD SPLICE SECTION	50'	R.H.T.	NONE	51.1
1	5760	CABLE FIELD SPLICE SECTION	25'	R.H.T.	NONE	27.1
1	5840	CABLE FIELD REPAIR SECTION	5'	R.H.T.	L.H.T.	10.8

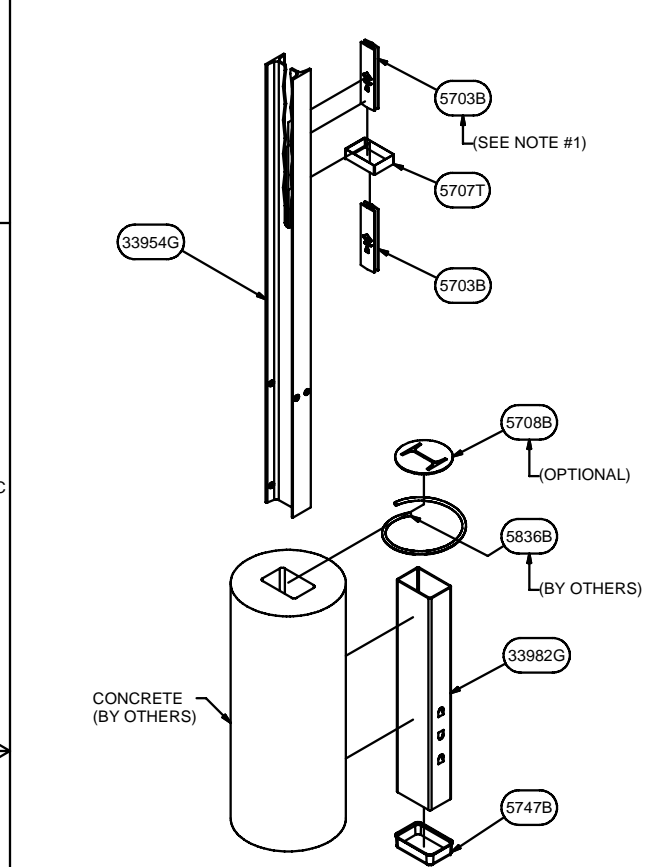

CASS-TL4 POST - IN CONCRETE
(POST OPTION #3 - CAST IN PLACE)

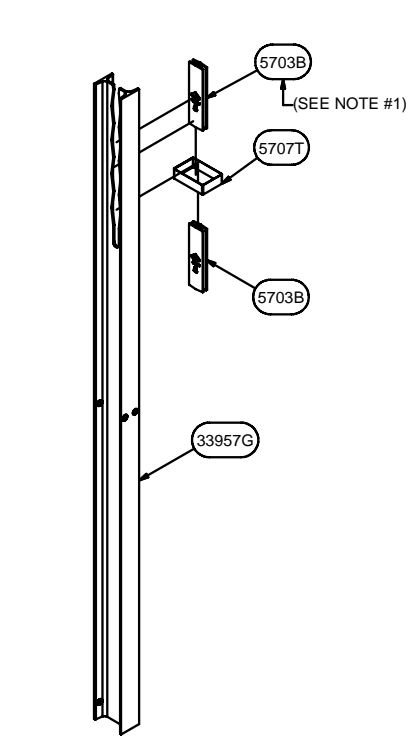

CASS-TL4 POST - DRIVEN
(POST OPTION #4 - DRIVEN)

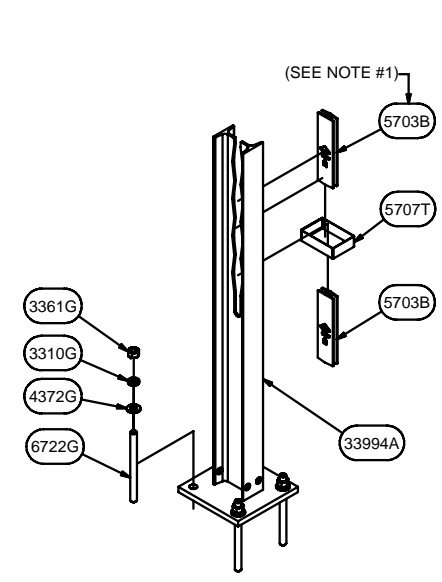

CASS-TL4 POST - BASE-PLATED
(POST OPTION #5 - BASE-PLATED)

- ANCHOR OPTIONS:**
- 5/8 x 8" ALL THREADED ROD (A449) WITH EPOXY.
 - 5/8 MECHANICAL ANCHOR.
- (MIN. EMBEDMENT IN CONCRETE = 6".
MIN. PULLOUT STRENGTH = 10,000 lbs.)

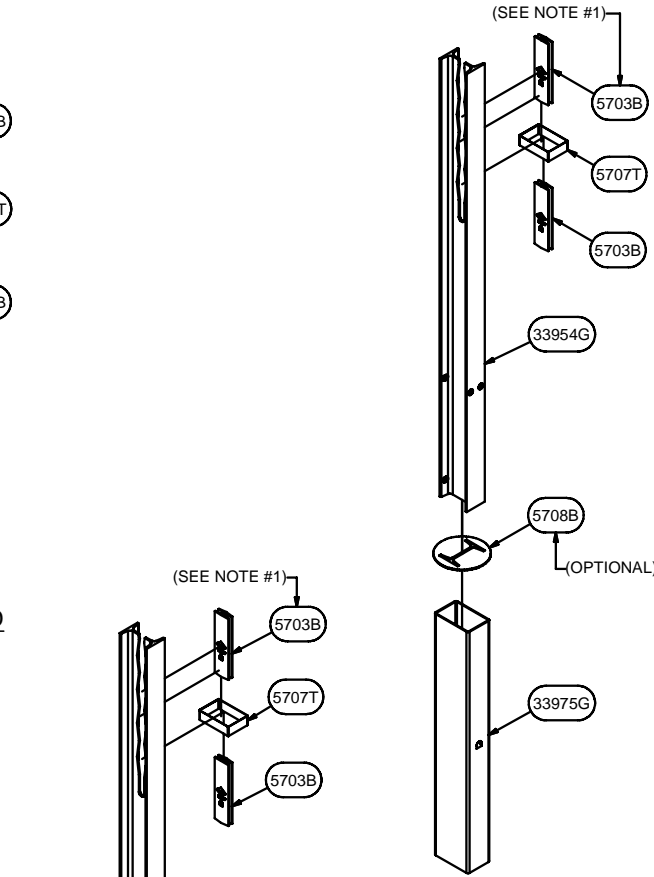

CASS-TL4 POST - IN DRIVEN SLEEVE
(POST OPTION #6A - DRIVEN SLEEVE - NOTCH)

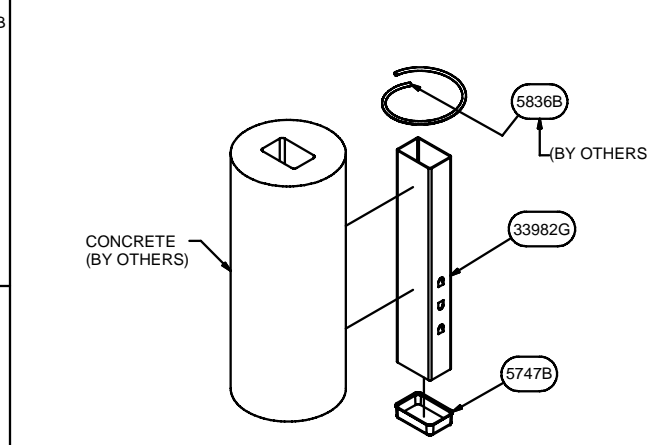

CONCRETE FOOTING ASSEMBLY
(POST OPTION #3 - PRE-CAST OPTION)

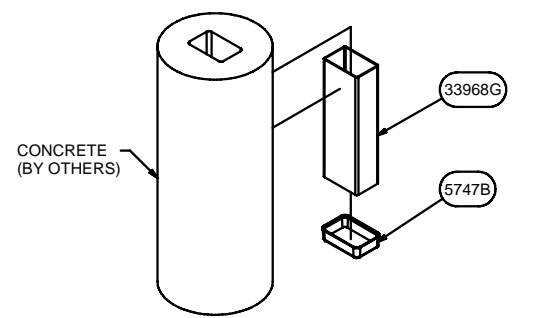

CONCRETE FOOTING ASSEMBLY
(INSTALLED IN QUALIFYING MOW STRIP SEE CHART SHEET 1)

CASS-TL4 POST - IN DRIVEN SLEEVE
(POST OPTION #6B - DRIVEN SLEEVE - SOIL PLATE)

PARTS LIST - PRE-CAST CONCRETE FOOTING - OPTION #3			
QTY	PART No	TITLE	Lbs / Each
1	5747B	SLEEVE CAP - CASS-TL POST	0.14
1	5836B	CONCRETE REINFORCING RING	0.88
1	33982G	27" POST SLEEVE - IN CONCRETE	14.48

PARTS LIST - CONCRETE FOOTING IN MOW STRIP OR PAVEMENT			
QTY	PART No	TITLE	Lbs / Each
1	5747B	SLEEVE CAP - CASS-TL POST	0.14
1	33968G	15" POST SLEEVE - CONCRETE POST	8.00

PARTS LIST - CASS-TL4 POST - IN DRIVEN SLEEVE - POST OPTION #6B			
QTY	PART No	TITLE	Lbs / Each
2	5703B	CASS-TL4 CABLE SPACER	0.24
1	5707T	CASS-TL - POST STRAP	0.23
1	5708B	SLEEVE COVER - CASS-TL POST	0.11
1	33954G	CASS-TL4 POST - CONCRETE	34.50
1	33976A	30.75" CASS-TL3 POST SLEEVE w/ SOIL PLATE	30.02

NOTE:
FOR THE STANDARD FIELD SPLICE SECTIONS ABOVE, SUPPLY (1) RIGHT HAND THREADED STUD ASSEMBLY 5910G EACH.

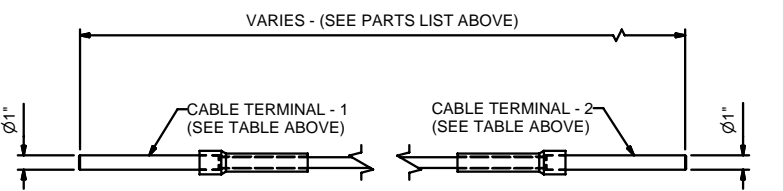

PRE-STRETCHED CABLE ASSEMBLY

- NOTES:**
- IN LIEU OF BLACK SPACER 5703B SUPPLY YELLOW REFLECTIVE SPACER 5705B OR WHITE REFLECTIVE SPACER 5706B. (AS REQUIRED PER PROJECT PLANS)
 - AT CASS-TL4 POST LOCATION NEAREST TO A CABLE SPLICE, SUPPLY A SPLICE INTERFERENCE POST.
LONG SPLICE POST 33984G IN LIEU OF LONG CASS-TL4 POST 33957G
SHORT SPLICE POST 33974G IN LIEU OF SHORT CASS-TL4 POST 33954G
 - IF REQUIRED PER PROJECT PLANS SUPPLY:
CABLE PULLING TOOL 5850B
CABLE TENSION METER 5878B
CABLE THERMOMETER 5709B

<p align="center">CASS-TL4 CABLE GUARDRAIL SAFETY SYSTEM</p>		GALV SPEC:
		SHIPPING WT:
<p align="center">TRINITY HIGHWAY PRODUCTS, LLC</p>		DRW: E.A.S. 6/13/2007
		CHK: G.N. 6/13/2007
PROJ: CASS-TL4	DWG NO:	REV
	SS-740	0

CASS TEMPERATURE & TENSION CHART (NEAREST 100 lb/F)		
FAHRENHEIT DEGREES	STD. CABLE LB/FORCE	PRE-STRETCHED LB/FORCE
<= -15	8800	7500
-10	8600	7300
-5	8400	7100
0	8200	7000
5	8000	6800
10	7800	6600
15	7600	6500
20	7400	6300
25	7200	6100
30	7000	6000
35	6800	5800
40	6600	5600
45	6400	5500
50	6200	5300
55	6000	5100
60	5800	5000
65	5600	4800
70	5400	4600
75	5200	4500
80	5000	4300
85	4800	4100
90	4600	4000
95	4400	3800
100	4200	3600
105	4000	3500
110	3800	3300
115	3600	3100
120	3400	3000
125	3200	2800
130	3000	2700
135	2900	2600
140	2700	2500
145	2500	2400
150	2400	2300
160	2200	2100
170	2000	1900
180	1800	1700
190	1600	1500
200	1400	1300

ALLOWABLE DEVIATION FROM CHART: 200 POUNDS/FORCE.

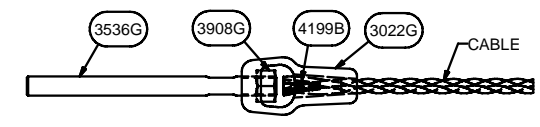

1" CABLE FIELD SPLICE - 5909G & 5910G
(5910G SHOWN, 5909G SIMILAR)

PARTS LIST - 5910G			
QTY	PART No	TITLE	Lbs / Each
1	3022G	1" CABLE END CASTING	0.56
1	3536G	1" STUD FLATTENED - R.H.T.	2.88
1	3908G	1" HEAVY HEX NUT (A563 DH)	0.47
1	4199B	3/4" CABLE WEDGE (3 x 7)	0.08

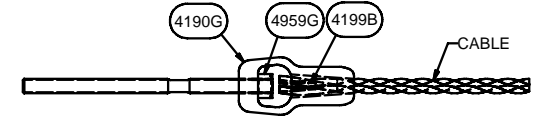

3/4" CABLE FIELD SPLICE - 5634G & 5635G
(5634G SHOWN, 5635G SIMILAR)

PARTS LIST - 5634G			
QTY	PART No	TITLE	Lbs / Each
1		3/4" STUD FLATTENED - L.H.T.	1.62
1	4190G	CABLE END CASTING	3.78
1	4199B	3/4" CABLE WEDGE (3 x 7)	0.08
1	4959G	3/4" HEAVY SQUARE NUT (A563)	0.26

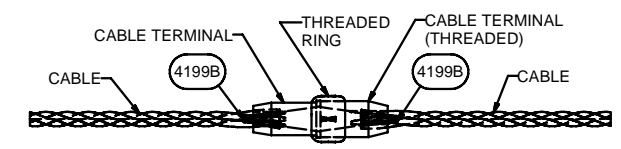

TORPEDO CABLE SPLICE - 4099G

PARTS LIST - 4099G			
QTY	PART No	TITLE	Lbs / Each
1		CABLE TERMINAL - THREADED	1.78
1		CABLE TERMINAL	1.52
1		RING - THREADED	-0.06
2	4199B	3/4" CABLE WEDGE (3 x 7)	0.08

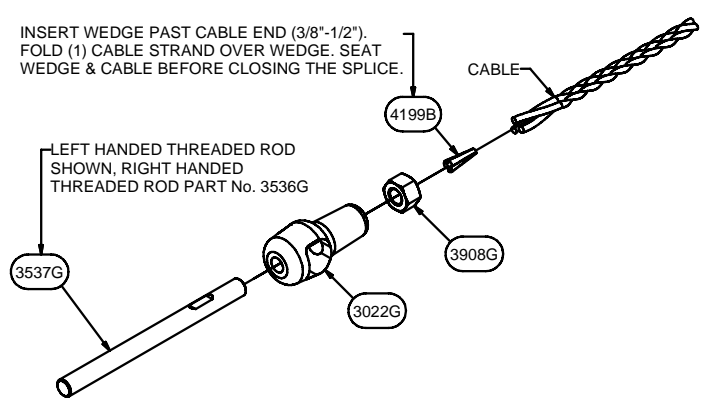

ASSEMBLY - 1" CABLE FIELD SPLICE - 5909G
(5909G SHOWN, 5910G SIMILAR)

PARTS LIST - 5909G			
QTY	PART No	TITLE	Lbs / Each
1	3022G	1" CABLE END CASTING	0.56
1	3537G	1" STUD FLATTENED - L.H.T.	2.88
1	3908G	1" HEAVY HEX NUT (A563 DH)	0.47
1	4199B	3/4" CABLE WEDGE (3 x 7)	0.08

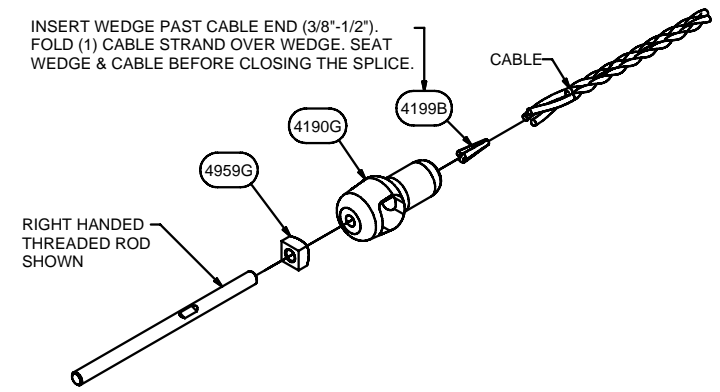

ASSEMBLY - 3/4" CABLE FIELD SPLICE - 5635G
(5635G SHOWN, 5634G SIMILAR)

PARTS LIST - 5635G			
QTY	PART No	TITLE	Lbs / Each
1		3/4" STUD FLATTENED - R.H.T.	1.62
1	4190G	CABLE END CASTING	3.78
1	4199B	3/4" CABLE WEDGE (3 x 7)	0.08
1	4959G	3/4" HEAVY SQUARE NUT (A563)	0.26

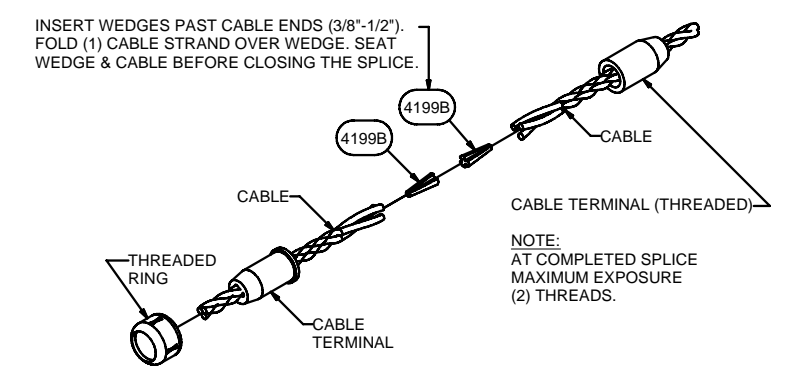

ASSEMBLY - TORPEDO CABLE SPLICE 4099G

NOTE:
AT COMPLETED SPLICE
MAXIMUM EXPOSURE
(2) THREADS.

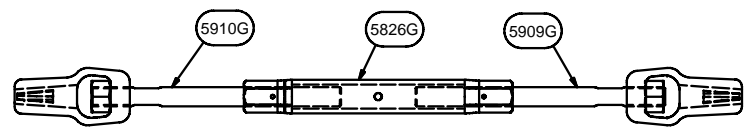

1" CABLE SPLICE - 5633G
(CLOSED BODY STYLE)

PARTS LIST - 5633G				
QTY	PART No	ITEM	TITLE	Lbs / Each
1	5826G	1	1" CASS TURNBUCKLE CLOSED BODY STYLE	4.81
1	5909G	2	1" STUD ASSEMBLY L.H.T.	3.99
1	5910G	3	1" STUD ASSEMBLY R.H.T.	3.99

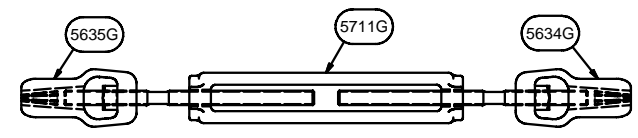

3/4" CABLE SPLICE - 5698G
(OPEN BODY STYLE)

PARTS LIST - 5698G			
QTY	PART No	TITLE	Lbs / Each
1	5634G	3/4" STUD ASSEMBLY L.H.T.	5.74
1	5635G	3/4" STUD ASSEMBLY R.H.T.	5.74
1	5711G	3/4" TURNBUCKLE OPEN BODY STYLE	10.69

NOTE:

- TURNBUCKLES SHALL BE INSTALLED WITH A MINIMUM OF 1-1/2" THREAD ENGAGEMENT. TO ALLOW FOR MAINTENANCE/REPAIR ADJUSTMENTS AT A LATER DATE, TRINITY SUGGESTS INSTALLER UTILIZE NO MORE THAN 4" THREAD ENGAGEMENT.
- WHEN CUTTING CABLE LENGTHS IN THE FIELD FROM CABLE REELS, IT MAY BE PERMISSIBLE TO UTILIZE A CABLE TORPEDO SPLICE (4099G) BETWEEN TURNBUCKLES. DO NOT USE FOR CABLE LENGTH SHORTER THAN 100'. PLEASE CONTACT TRINITY, CONSULT TRINITY'S MANUAL OR SPECIFYING AGENCY TO DETERMINE IF APPROPRIATE FOR SPECIFIC APPLICATION.

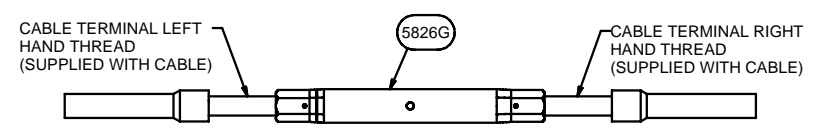

1" TURNBUCKLE - 5826G
(CLOSED BODY STYLE)

PARTS LIST - 5826G				
QTY	PART No	ITEM	TITLE	Lbs / Each
1	5826G	1	1" CASS TURNBUCKLE CLOSED BODY STYLE	4.81

PROJ. CASS-TL4

CASS-TL4 CABLE GUARDRAIL SAFETY SYSTEM		GALV SPEC:	
		SHIPPING WT:	
DRW: E.A.S. 6/13/2007		CHK: G.N. 6/13/2007	
SHT: 3 OF 5		SIZE: D	
DWG NO: SS-740		REV: 0	

TRINITY HIGHWAY PRODUCTS, LLC

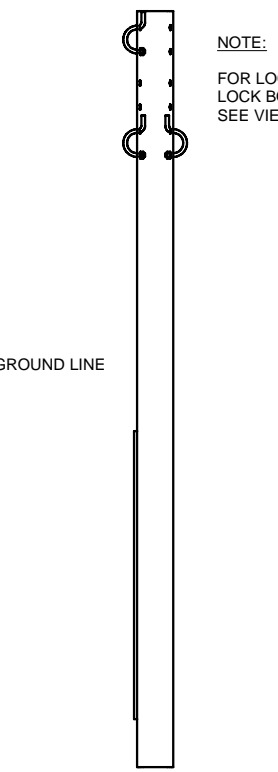
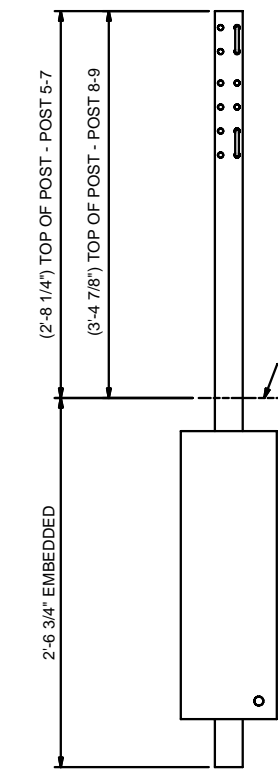
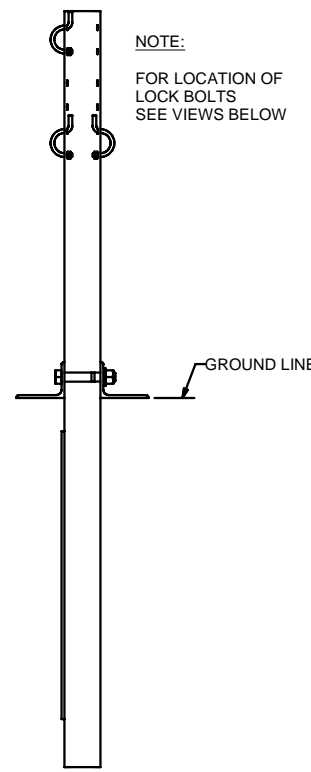
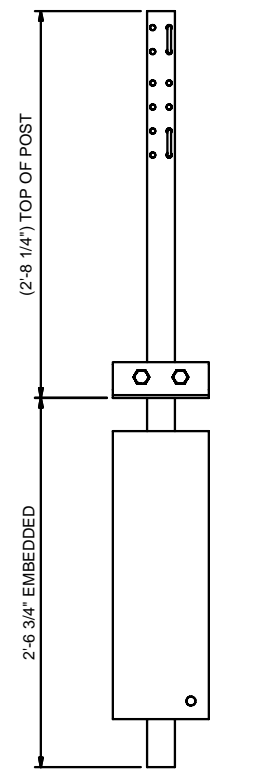
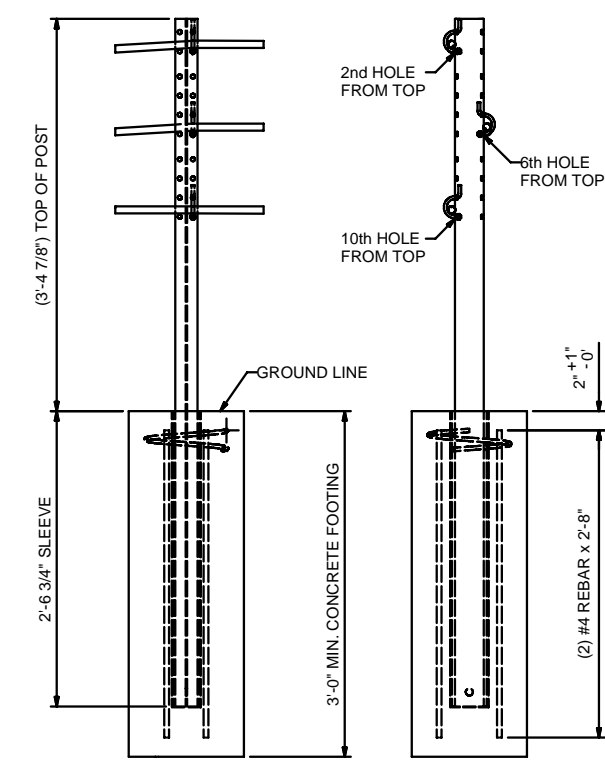
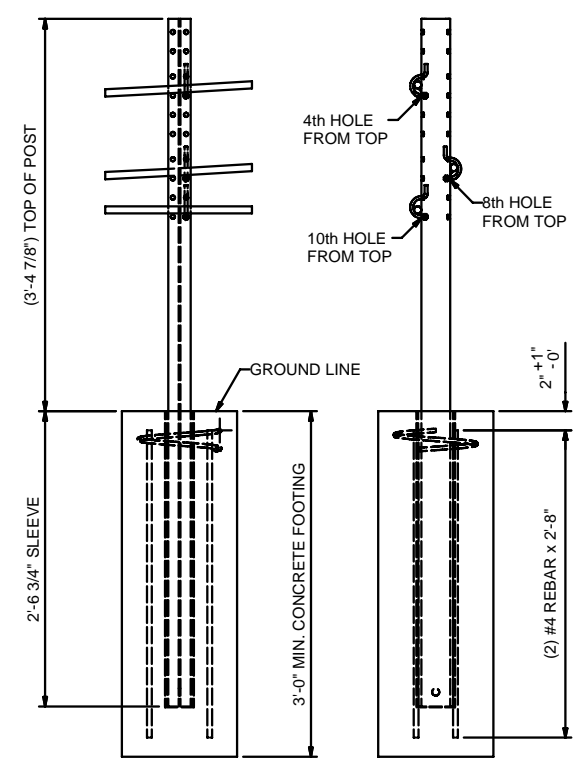
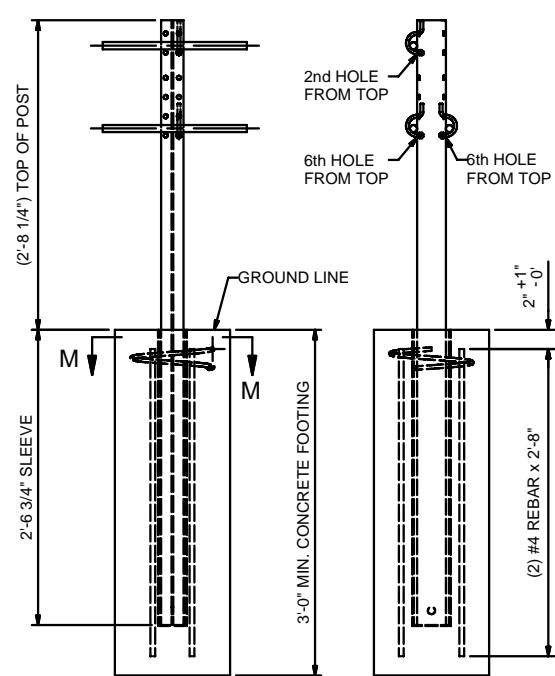
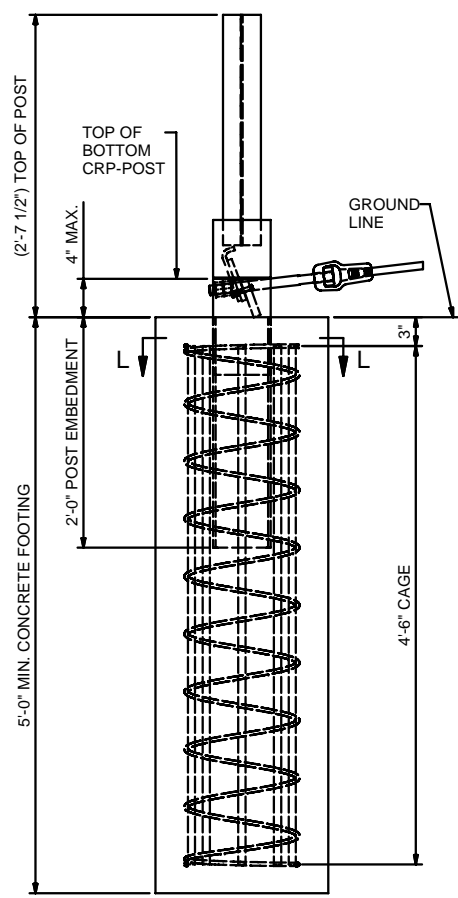
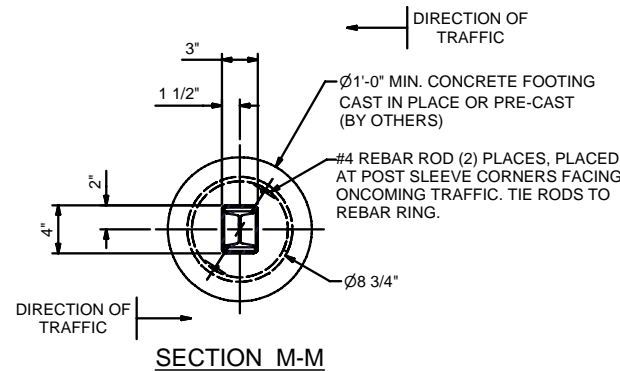
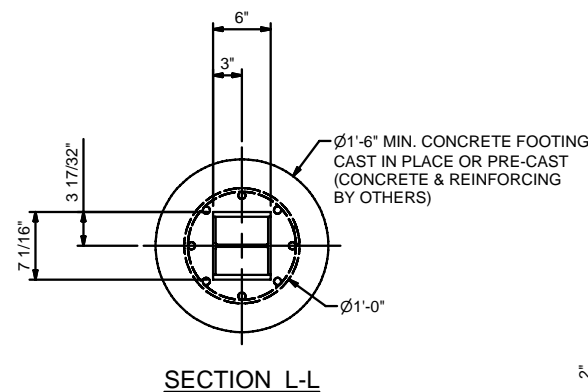
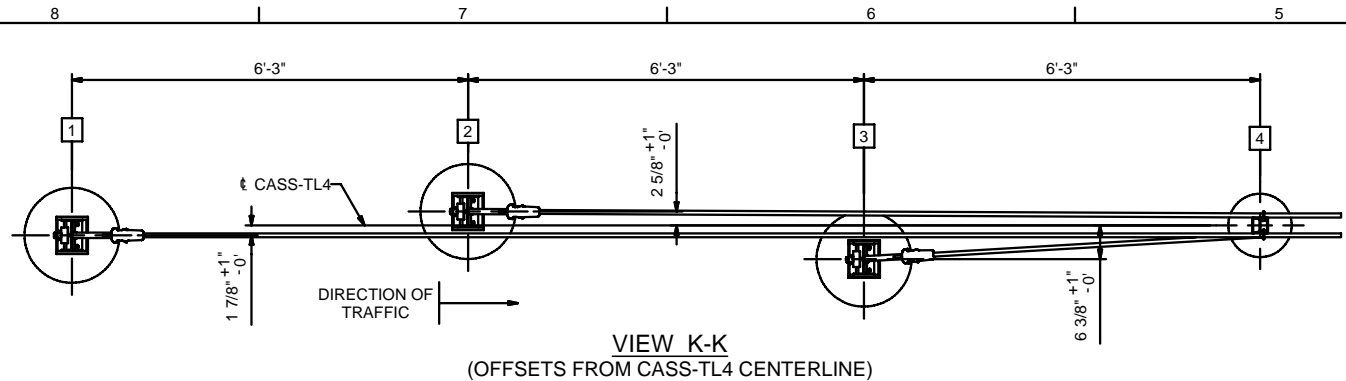

NOTE:
FOR LOCATION OF
LOCK BOLTS
SEE VIEWS BELOW

NOTE:
FOR LOCATION OF
LOCK BOLTS
SEE VIEWS BELOW

CASS-TL4 CABLE GUARDRAIL SAFETY SYSTEM		GALV SPEC:	
		SHIPPING WT:	
DRW: E.A.S. 6/13/2007		CHK: G.N. 6/13/2007	
SHT: 4 OF 5		SIZE: D	
TRINITY HIGHWAY PRODUCTS, LLC		DWG NO:	REV
PROJ: CASS-TL4		SS-740	0

PARTS LIST - CCT CABLE RELEASE POST No. 1-3 - IN CONCRETE			
QTY	PART No	TITLE	Lbs / Each
1		CONCRETE FOOTING - CRP POST	1274.12
2	3248G	5/16 HEX BOLT x 2" (SAE Gr.5)	0.06
2	5831G	5/16 FLAT WASHER (SAE Gr.5)	0.01
2	5832G	5/16 DIA. HEX NUT (SAE Gr.5)	0.01
1	5851B	REFLECTOR - MEDIAN - YELLOW	0.10
1	33909G	CASS CABLE BRACKET	1.92
1	33916B	REINFORCING CAGE - CRP POST	68.07
1	33934A	CRP - LOWER POST	51.80
1	33935A	CRP - UPPER POST	31.57

PARTS LIST - CCT TERMINAL POST No. 4-7 - IN CONCRETE			
QTY	PART No	TITLE	Lbs / Each
1		CONCRETE FOOTING - LINE POST	309.19
3	3245G	5/16 DIA. HEX NUT (A563)	0.01
3	5825G	CABLE LOCK BOLT (A307)	0.12
1	5836B	CONCRETE REINFORCING RING	0.88
1	5839B	SLEEVE COVER - S3 ANCHOR POST	0.11
2	5919B	#4 REBAR - TERMINAL POST	1.78
1	33908G	SLEEVE - TERMINAL LINE POST	20.90
1	33910G	350-TL3 TERMINAL POST	28.63

PARTS LIST - CCT CABLE RELEASE POST No. 1-3 - DRIVEN			
QTY	PART No	TITLE	Lbs / Each
2	3248G	5/16 HEX BOLT x 2" (SAE Gr.5)	0.06
2	5831G	5/16 FLAT WASHER (SAE Gr.5)	0.00
2	5832G	5/16 DIA. HEX NUT (SAE Gr.5)	0.01
1	33909G	CASS CABLE BRACKET	1.92
1	33935A	CRP - UPPER POST	31.57
1	33936A	CRP - LOWER POST	178.57

PARTS LIST - CCT TERMINAL POST No. 4 - WITH SOIL PLATE			
QTY	PART No	TITLE	Lbs / Each
3	3245G	5/16 DIA. HEX NUT (A563)	0.01
2	3701G	3/4 FLAT WASHER (F436)	0.01
2	3711G	3/4 HEX NUT (A194 2H)	0.02
2	4779G	3/4 HEX BOLT x 4 1/2" (A325)	0.09
3	5825G	CABLE LOCK BOLT (A307)	0.12
2	9021G	BEARING ANGLE (A36)	3.81
1	33903A	350-TL3 TERMINAL POST w/ SOIL PLATE	42.25

PARTS LIST - CCT TERMINAL POST No. 5-7 - WITH SOIL PLATE			
QTY	PART No	TITLE	Lbs / Each
3	3245G	5/16 DIA. HEX NUT (A563)	0.01
3	5825G	CABLE LOCK BOLT (A307)	0.12
1	33903A	350-TL3 TERMINAL POST w/ SOIL PLATE	42.25

PARTS LIST - CCT TERMINAL POST No. 8-9 - WITH SOIL PLATE			
QTY	PART No	TITLE	Lbs / Each
3	3245G	5/16 DIA. HEX NUT (A563)	0.01
3	5825G	CABLE LOCK BOLT (A307)	0.12
1	33989A	350-TL4 TERMINAL POST w/ SOIL PLATE	46.02

CCT HARDWARE NOTE:
 5832G (5/16" GRADE 5 NUT) WILL BE REPLACED BY 3245G (5/16" A563 NUT)
 5831G (5/16" GRADE 5 WASHER) WILL BE REPLACED BY 3240G (5/16" ROUND WASHER)
 3248G (5/16" GRADE 5 X 2" BOLT) WILL BE REPLACED BY 4211G (5/16" X 1 3/4" A307 BOLT)

ALL HARDWARE FOR THE CCT CAN BE ORDERED AS ONE PACKAGE:
 PART No. 33570G: (1) SET OF TERMINAL HARDWARE FOR 1" CABLE FITTINGS.
 PART No. 33566G: (2) SETS OF TERMINAL HARDWARE FOR 1" CABLE FITTINGS.
 PART No. 33567G: (1) SET OF TERMINAL HARDWARE FOR 3/4" CABLE FITTINGS.
 PART No. 33568G: (2) SETS OF TERMINAL HARDWARE FOR 3/4" CABLE FITTINGS.

(OPTIONAL) USE PART No 5852B FOR SHOULDER INSTALLATIONS

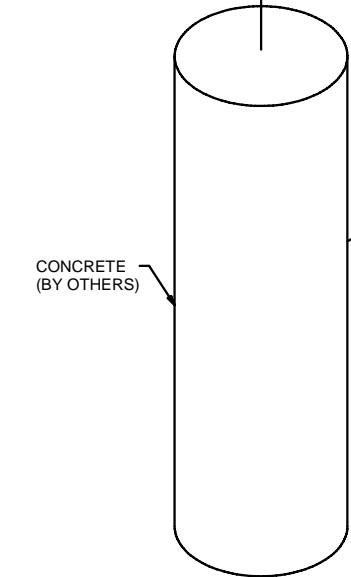
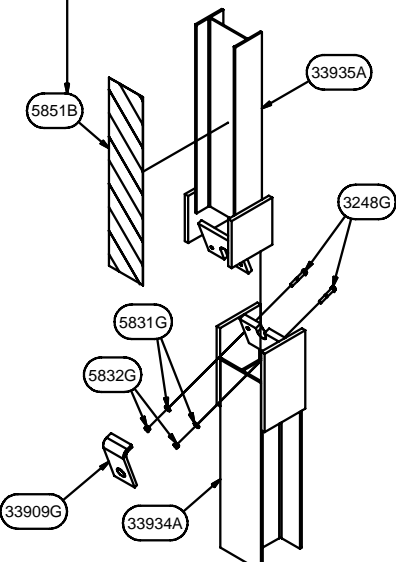

CRP TERMINAL POST - IN CONCRETE
 (CCT TERMINAL POST 1 - 3)
 (POST OPTION #1 SHOWN)

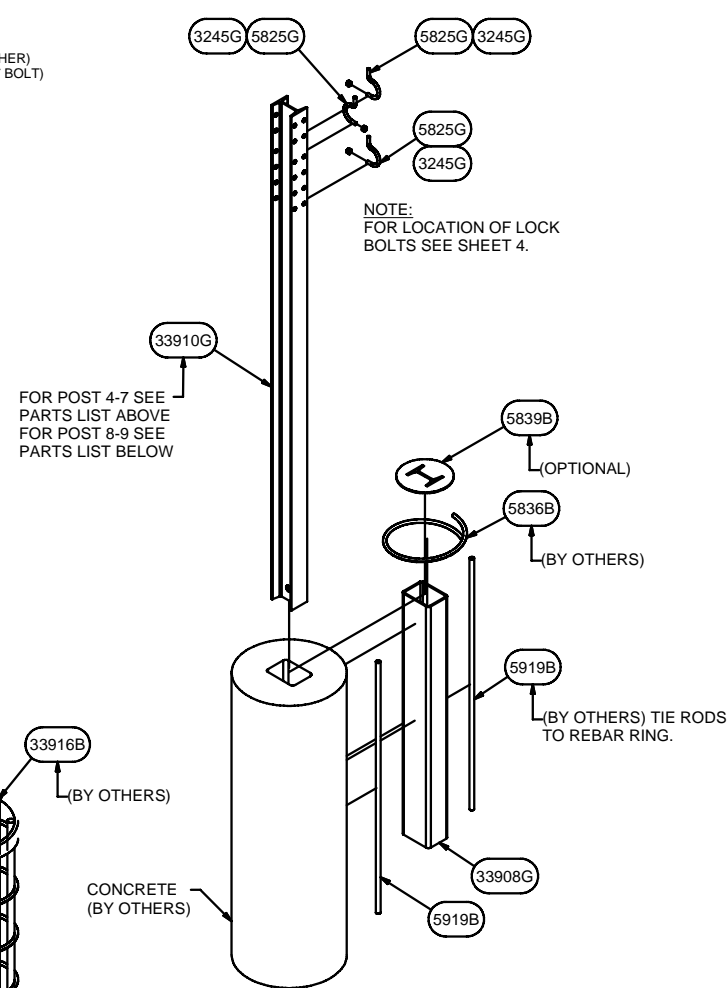

TERMINAL LINE POST - IN CONCRETE
 (CCT TERMINAL POST 4 - 7)
 (POST OPTION #1 SHOWN)

PARTS LIST - CCT TERMINAL POST No. 8-9 - IN CONCRETE			
QTY	PART No	TITLE	Lbs / Each
1		CONCRETE FOOTING - LINE POST	309.19
3	3245G	5/16 DIA. HEX NUT (A563)	0.01
3	5825G	CABLE LOCK BOLT (A307)	0.12
1	5836B	CONCRETE REINFORCING RING	0.88
1	5839B	SLEEVE COVER - S3 ANCHOR POST	0.11
2	5919B	#4 REBAR - TERMINAL POST	1.78
1	33908G	SLEEVE - TERMINAL LINE POST	20.90
1	33955G	350-TL4 TERMINAL POST	32.42

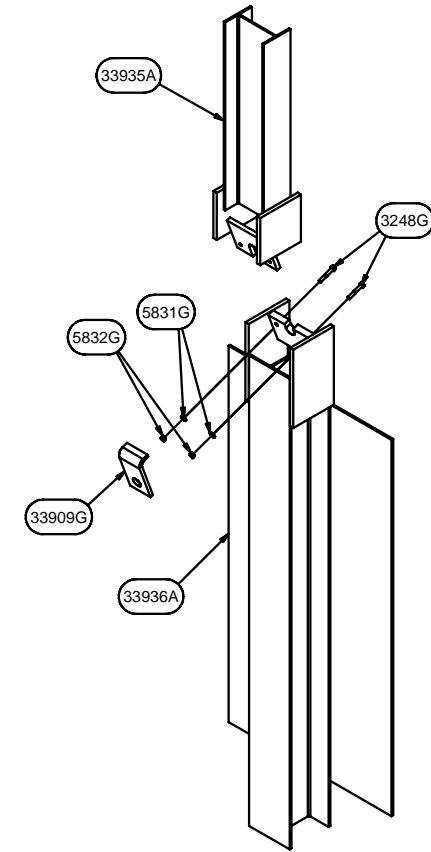

CRP TERMINAL POST - DRIVEN
 (CCT TERMINAL POST 1 - 3)
 (POST OPTION #2 SHOWN)

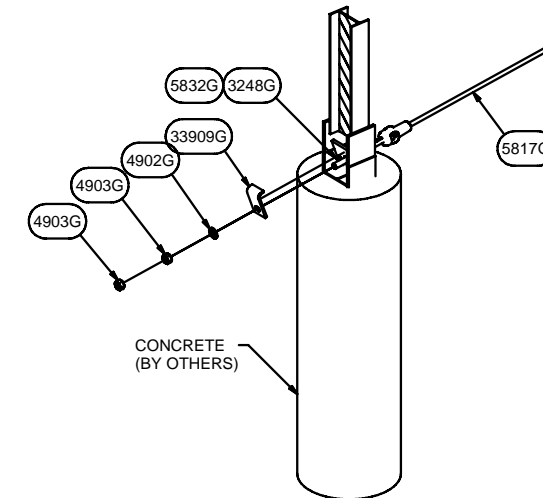

CONCRETE (BY OTHERS)

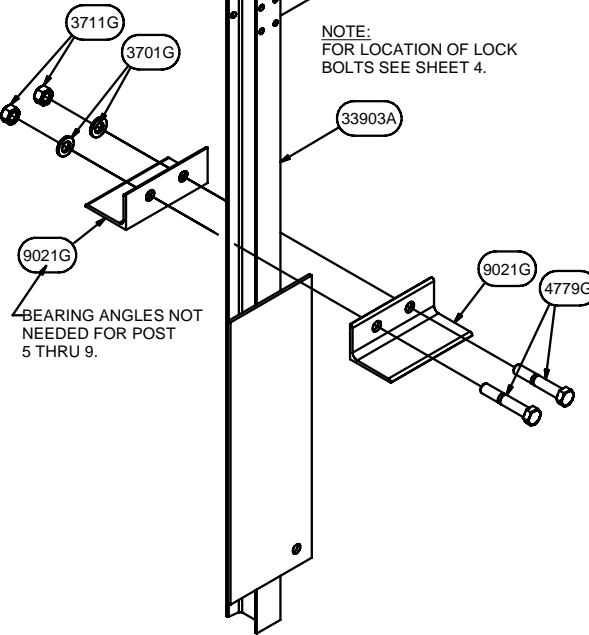

TERMINAL LINE POST - WITH SOIL PLATE
 (CCT TERMINAL POST - 4)
 (POST OPTION #2 SHOWN)

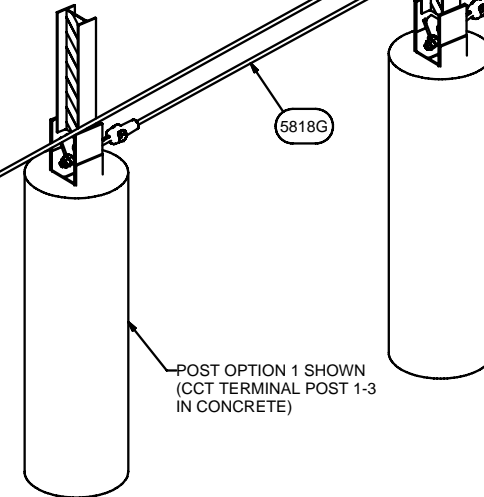

CASS-TL4 CABLE TERMINAL
 (SHOWN WITH POST OPTION 1)

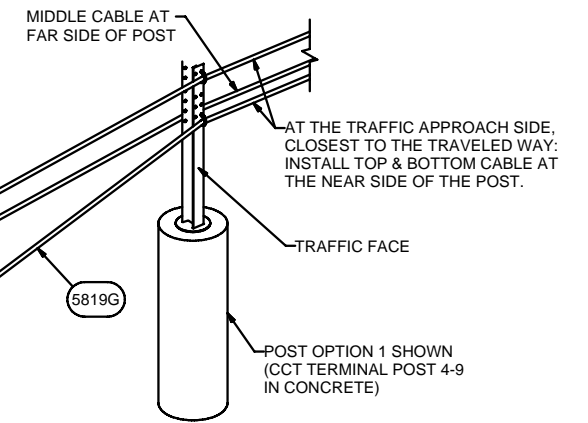

HARDWARE CASS CABLE TERMINAL - CCT			
QTY	PART No	TITLE	Lbs / Each
6	3248G	5/16 HEX BOLT x 2" (SAE Gr.5)	0.06
3	4902G	1" FLAT WASHER (F436)	0.11
6	4903G	1" HEX NUT (A194 2H)	0.33
1	5817G	CRP - TOP CABLE ASSEMBLY [54'-3"]	101.81
1	5818G	CRP - MIDDLE CABLE ASSEMBLY [48'-0"]	92.34
1	5819G	CRP - BOTTOM CABLE ASSEMBLY [41'-9"]	83.04
6	5831G	5/16 FLAT WASHER (SAE Gr.5)	0.01
6	5832G	5/16 DIA. HEX NUT (SAE Gr.5)	0.01
3	33909G	CASS CABLE BRACKET	1.92

CASS-TL4 CABLE GUARDRAIL SAFETY SYSTEM		GALV SPEC:
		SHIPPING WT:
TRINITY HIGHWAY PRODUCTS, LLC		DRW: E.A.S. 6/13/2007
		CHK: G.N. 6/13/2007
PROJ: CASS-TL4		SHT: 5 OF 5 SIZE: D
DWG NO: SS-740		REV: 0